



# HF-Regulator II for TL5 lamps

## HF-R 2 14-35 TL5 EII 220-240V 50/60Hz

High-frequency electronic dimming ballast, using the analog protocol (1-10 V) for TL5 HE/HO and TL5 Eco lamps

### Product data

General Information		Power losses (nom.)	
Application code	EII		5.3-6.5 W
Type version	mk1	Inrush current peak (max.)	45 A
Lamp type	TL5	<b>Wiring</b>	
Number of lamps	2 piece/unit	Connector type input terminals	WAGO 251 universal connector [ Suitable for both automatic wiring (ALF and ADS) and manual wiring]
Number of products on MCB (16 A type B) (nom.)	12	Connector type output terminals	WAGO 251 universal connector [ Suitable for both automatic wiring (ALF and ADS) and manual wiring]
Automatic restart	Yes	Connector type control input terminals	WAGO 251 universal connector [ Suitable for both automatic wiring (ALF and ADS) and manual wiring]
<b>Operating and Electrical</b>		Wire strip length	8.0-9.0 mm
Input Voltage	220 to 240 V	Dual fixture master/slave	- [ not specified]
Input frequency	50 to 60 Hz	Control input terminal cross section	0.50-1.00 mm <sup>2</sup>
Operating frequency (max.)	100 kHz	Input terminal cross section	0.50-1.00 mm <sup>2</sup>
Operating frequency (min.)	46 kHz	Output terminal cross section	0.50-1.00 mm <sup>2</sup>
Ignition method	Programmed Start	Auto-insert (ALF/ADS) wire cross section	0.5 mm <sup>2</sup>
Crest factor (max.)	1.7	<b>System characteristics</b>	
Power factor 100% load (nom.)	0.98	Rated ballast-lamp power	14-35 W
Ignition time (max.)	0.2 s		
Mains voltage performance (AC)	-8%~+6%		
Mains voltage safety (AC)	-10%~+10%		
Earth leakage current (max.)	0.5 mA		
Inrush current width	0.40 ms		

## HF-Regulator II for TL5 lamps

Temperature	
T-ambient (max.)	50 °C
T-ambient (min.)	-20 °C
T storage (max.)	80 °C
T storage (min.)	-25 °C
Stable lamp operation temperature	Not Specified
T-Ignition (max.)	50 °C
T-Ignition (min.)	0 °C

Controls and Dimming	
Control interface	1-10V
Regulating level power	1%-100%
Control input protection	Yes (Basic insulation)

Mechanical and Housing	
Housing	L 360x30x21

Emergency Operation	
Battery voltage lamp ignition	196 V
Battery voltage lamp operation	154-276

Approval and Application	
Energy efficiency index	A1 BAT
IP classification	IP 20 [ Ingress Protection 20]
EMI 9 kHz ... 30 MHz	EN55015
EMI 30 MHz ... 1,000 MHz	EN55022 level B

Safety standard	IEC 61347-2-3
Performance standard	IEC 60929
Quality standard	ISO 9000:2000
Environmental standard	ISO 14001
Harmonic current emission standard	IEC 61000-3-2
EMC immunity standard	IEC 61547
Vibration standard	IEC68-2-6 F c
Bumps standard	IEC 68-2-29 Eb
Humidity standard	EN 61347-2-3 clause 11
Approval marks	CE marking ENEC certificate VDE-EMV certificate
Temperature marking	Yes
Emergency standard	IEC 60598-2-22
Humming and noise level	Inaudible

Product Data	
Full product code	871150091178030
Order product name	HF-R 2 14-35 TL5 EII 220-240V 50/60Hz
EAN/UPC – product	8711500911780
Order code	91178030
SAP numerator – quantity per pack	1
SAP numerator – packs per outer box	12
Material no. (12 NC)	913700619566
SAP net weight (piece)	0.290 kg

### Dimensional drawing

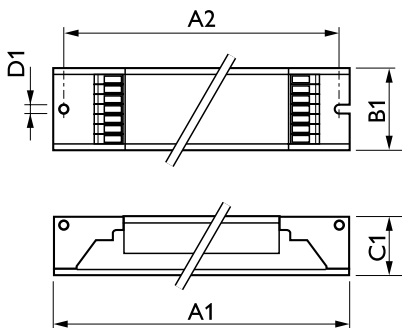

HF-R 2 14-35 TL5 EII 220-240V 50/60Hz

Product
HF-R 2 14-35 TL5 EII 220-240V 50/60Hz

## HF-Regulator II for TL5 lamps

